

REVISION CHANGES:

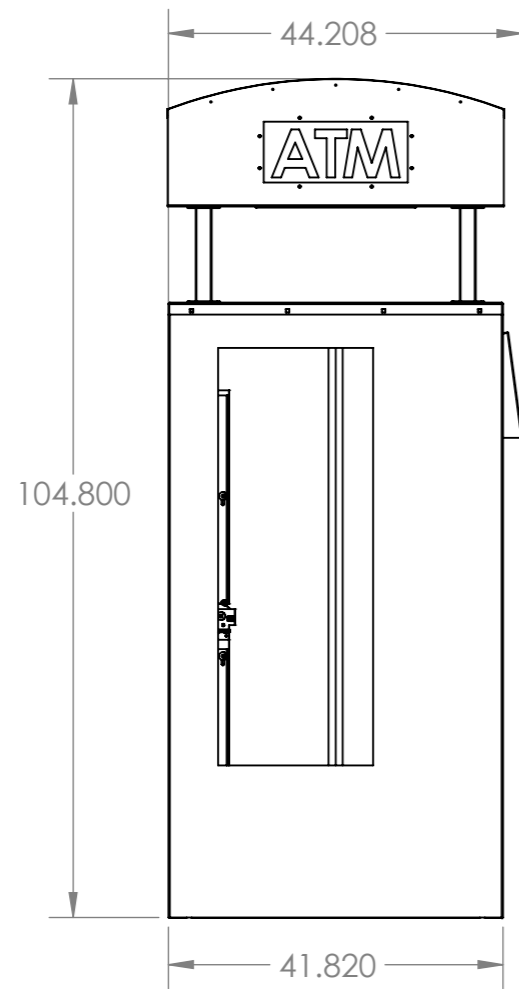

FRONT VIEW

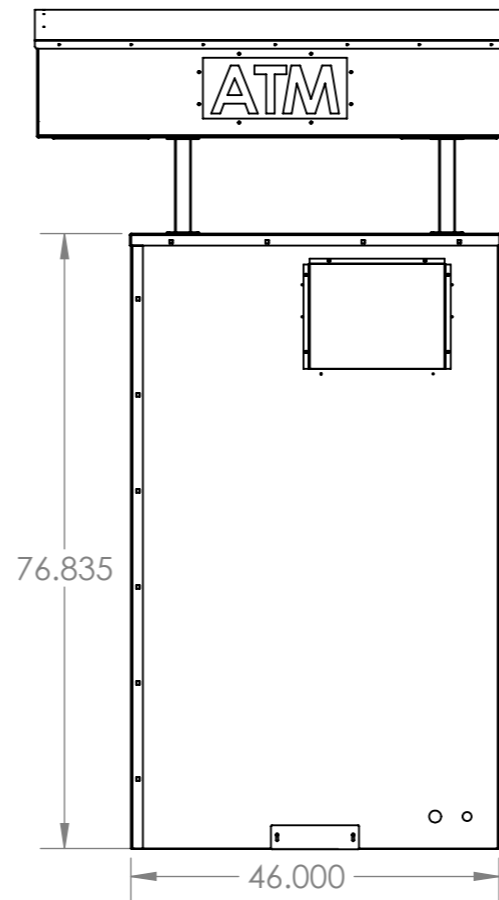

RIGHT SIDE VIEW

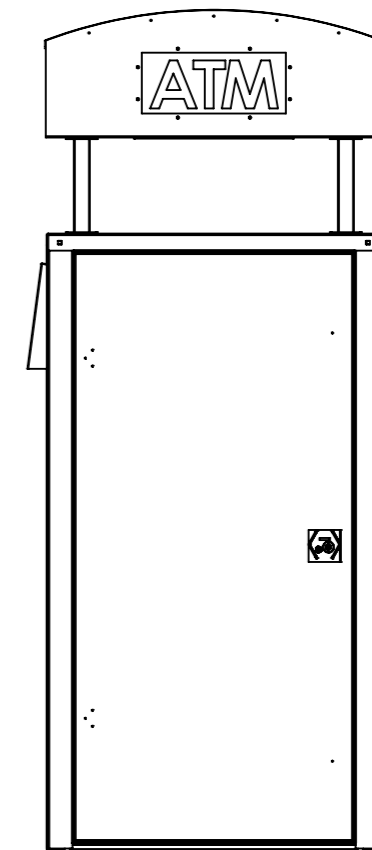

REAR DOOR VIEW

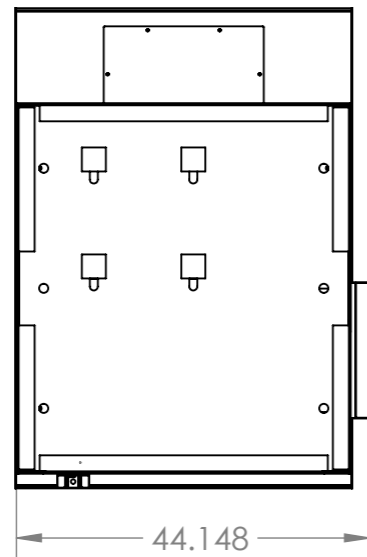

44.148

LAST SAVED DATE: 7/26/2016

TPI
 972-276-2901 FAX 972-276-3451
 1136 N. FIRST ST. GARLAND, TX. 75040
 www.tpitexas.com

UNLESS OTHERWISE SPECIFIED: DIMENSIONS ARE IN INCHES SURFACE FINISH: TOLERANCES: 3 PLC ±.005 LINEAR: 2 PLC ±.010 ANGULAR: ±1°				FINISH: PAINT		DEBUR AND BREAK SHARP EDGES		TITLE: GT-3000	
DRAWN	NAME	SIGNATURE	DATE						
CHK'D								DWG NO.	
APPV'D				DO NOT SCALE DRAWING					
MFG				SCALE:1:24				A3	
Q.A				MATERIAL:					
				WEIGHT:		SHEET 1 OF 1		REVISION -	