

REVISION CHANGES:
 REV A - REDESIGNED (MOSTLY THE BASE) 10-24-16

ITEM NO.	PART NUMBER	DESCRIPTION	MATERIAL	COMPANYNAME	QTY.
1	RND-1822 Base ASM	BASE ASM	.125 ALUM 5052	ATM/RND-1822	1
2	RND-1822-12 Wrapper-R	WRAPPER, RIGHT	.090 ALUM 5052	ATM/RND-1822	1
3	RND-1822-12 Wrapper-L	WRAPPER, LEFT	.090 ALUM 5052	ATM/RND-1822	1
4	RND-1822-130 Door ASM	EH-6A-5G5-50 DOOR ASM	ALUM 5052	ATM/RND-1822	1
5	RND-1822-140 Front Top ASM	FRONT TOP ASM	SEE -140 ASM	ATM/RND-1822	1
6	RND-1822-20 ATM Top	TOP	.090 ALUM 5052	ATM/RND-1822	1
7	RND-1822 Topper ASM	TOPPER ASM	SEE TOPPER ASM	ATM/RND-1822	1
8	RND-1822-30 Lock Pawl	CAM LOCK PAWL	11 GA SST	ATM/RND-1822	2
9	RND-1822-34 Lock Guard	LOCK GUARD	.060 ALUM 5052	ATM/RND-1822	2
10	RND-1810-260 Mount Foot ASM	MOUNT FOOT ASM	12 GA EG	ATM/RND-1810	4
11	RND-1810-BT Base Template	BASE MOUNT TEMPLATE	18 GA EG	ATM/RND-1810 MISC	1
12	-EH-6A-5G5-50	SOUTHCO HINGE			3
13	Keyed Lock Qtr Turn				2

ALIGN ATM TOP Ø.250 HOLE
 WITH SEAM ON RING

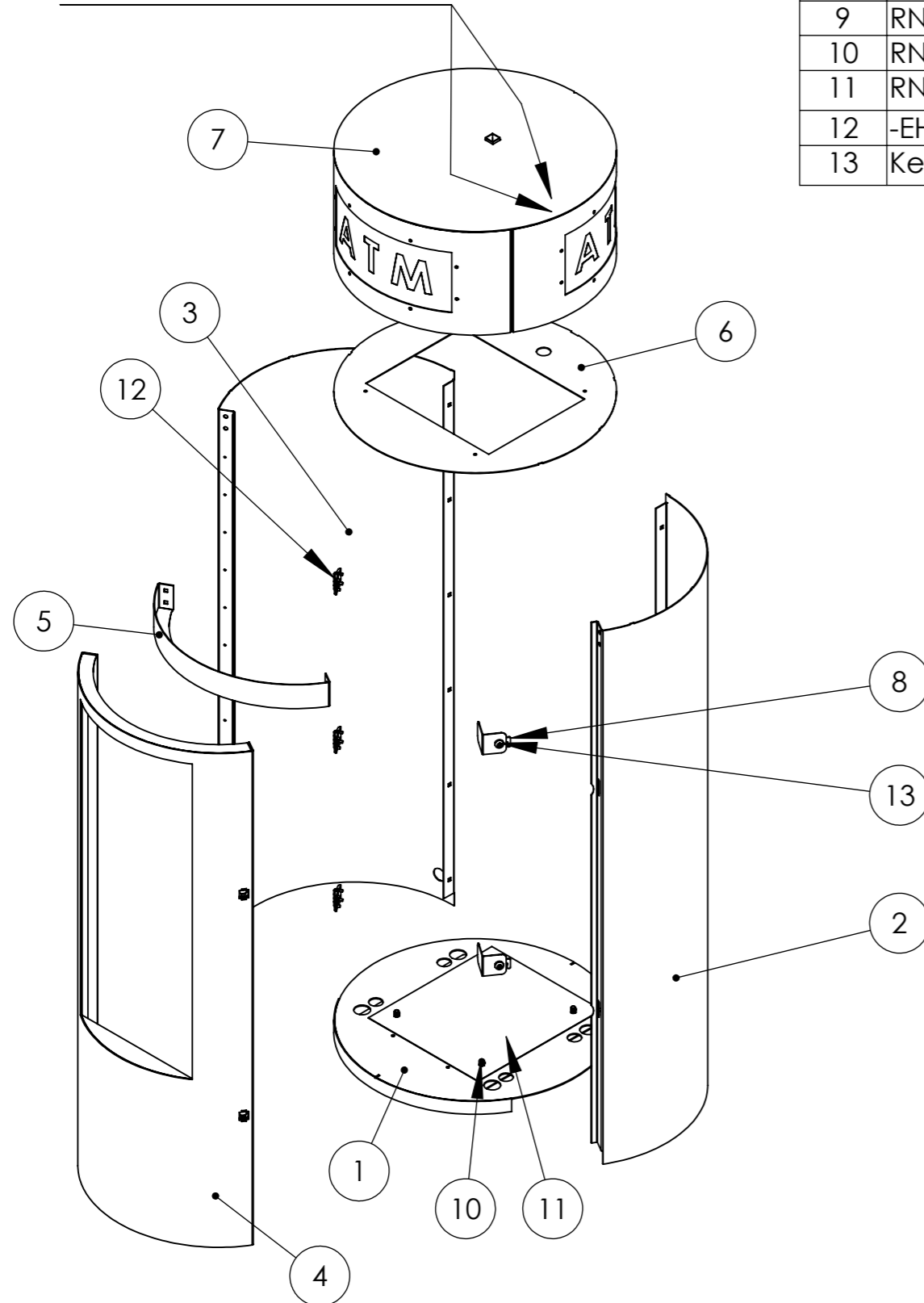

ASSEMBLY REQUIRES THE FOLLOWING:
 (10) 5/16 CARRIAGE BOLTS AND NUTS TO ATTACH ITEM 5 TO WRAPS
 (4) 1/4-20 WING NUTS TO ATTACHED TOPPER TO MAIN ASM

LAST SAVED DATE: 1/12/2017

UNLESS OTHERWISE SPECIFIED: DIMENSIONS ARE IN MILLIMETERS SURFACE FINISH: TOLERANCES: LINEAR: ANGULAR:		FINISH: PAINT	DEBUR AND BREAK SHARP EDGES	TPI 972-276-2901 FAX 972-276-3451 1136 N. FIRST ST. GARLAND, TX. 75040 www.tpitexas.com	
DRAWN	NAME	SIGNATURE	DATE	TITLE: ATM/ATM-1822 1822 ALUM ROUND ATM	
CHK'D				DWG NO. RND-1822 ASM	
APPV'D				A3	
MFG				SHEET 1 OF 2	
Q.A				REVISION A	
				WEIGHT:	

